



Products for Every Type of Building

STANLEY

STANLEY

STANLEY is one of the trademarks of Stanley Security Solutions, Inc.
All rights reserved.
© 2016 Stanley Security Solutions, Inc. 170202016

stanleyhardwareforall.com
Phone: 855-955-2407
611 EAST 75TH STREET
INDIANAPOLIS, IN 46250 USA

STANLEY

STANLEY: An Enduring Legacy

Frederick T. Stanley's vision was to create a hardware company with unsurpassed customer service, product innovation and integrity—one that would become the first choice among professionals around the world. That vision stands strong today with STANLEY.

With a long-standing history, a fearless commitment to growth and an emphasis on branding in the global marketplace well before it was an accepted business practice, STANLEY has become a trusted worldwide name for hardware on the openings of today's buildings. STANLEY continues to deliver innovative, high-quality products that have made the STANLEY name synonymous with the highest level of craftsmanship and dependability for more than 170 years.

Simply Innovative. Simply STANLEY.

STANLEY

A COMPLETE DOOR OPENING SOLUTION

Backed by a rich heritage of expertise and innovation, STANLEY offers an all-inclusive portfolio of products designed to work together as part of a complete security solution. Our mechanical locks, keys and cores, standard and narrow stile exit devices, hinges and door closers deliver quality you need at a price you can afford. Plus, with industry-best lead times and the ability to ship products from a single location, the STANLEY brand is certain to give you what you need—right when you need it.

PRODUCTS FOR EVERY TYPE OF OPENING

- **Grade 1 Locks:** Cylindrical, tubular, deadbolt, interconnected and mortise
- **Grade 1 Closers:** Full line of non-handed, interconnected and mortise
- **Grade 1 Exit Devices:** Available in a variety of architectural finishes
- **Grade 2 Tubular Locksets:** Mixed-use facility door hardware equipped with unique features like EasyPass™ and stylized rose options
- **Cores and Keys:** Available in many keyways and a variety of finishes to fit your application
- **Hinges:** Constructed with durable bearings and high-quality materials for long-lasting, maintenance-free operation
- **Grade 2 Tubular Locksets:** Mixed-use facility door hardware equipped with unique features like EasyPass™ and stylized rose options

With superior design, uncompromised materials and one of the industry's best lead times, it's no wonder that more customers and professionals trust STANLEY than any other brand.



STANLEY Door Hardware

STANLEY

STANLEY products are designed to fit a variety of commercial applications, from mixed-use developments with retail shops and multifamily housing, to other commercial buildings, such as offices, retail outlets and assisted living facilities.



Commercial Hardware: Reliable Security

Trusted Experts. Proven Reliability.

Customers trust STANLEY's history of proven performance and expertise. We never compromise on materials or craftsmanship, so we stand by the reliability and long-term durability of STANLEY Commercial Hardware products with limited lifetime mechanical warranties, as well as finish and electrical warranties you won't find on comparable products.

INNOVATION AT YOUR FINGERTIPS

STANLEY Commercial Hardware drives innovation to make leading-edge security more accessible, easier to install and simpler to maintain. We've engineered breakthroughs that make our products easy to configure and install with non-handed, field-reversible and field-sizeable options, easy-to-follow instructions and unique packaging designed to reduce installation time.

INDUSTRY-LEADING AVAILABILITY

STANLEY Commercial Hardware offers one of the industry's best lead times, with most products available to ship same day or next day. You can rely on STANLEY Commercial Hardware for in-stock, on-time security.

STANLEY Commercial Hardware proudly represents the high standards of the name your customers know and trust.

Commercial Hardware Locks

Our locks are engineered for long-lasting performance. STANLEY Commercial Hardware Grade 1 and Grade 2 locks—cylindrical, tubular, deadbolt, interconnect, and mortise—easily exceed industry standards for strength, durability, and tamper-resistance. Available in a variety of styles and finishes, our mechanical locks—with interchangeable cores and options for electrified functions—are easy to customize and configure in the field.

- LOCK SERIES TYPES**
- **QCL100 and QCL200 Series:** Heavy-duty and standard-duty cylindrical locks built to have an exceptionally reliable performance life
 - **QTL200 Series:** Standard-duty tubular locks that make installation and retrofitting simpler
 - **QDB100 and QDB200 Series:** Heavy-duty and standard-duty deadbolts with solid forged housing for added strength and performance life
 - **QC1200 Series:** Standard-duty interconnect locks with single motion egress for easy emergency exit
 - **QMS/QME100 Series:** Heavy-duty mortise locks with standard security features at a better value

Commercial Hardware Door Closers

Designed for maximum flexibility and optimal operational performance, STANLEY Commercial Hardware door closers significantly exceed ANSI Grade 1 standards, are fully field-adjustable and can be used in a wide range of applications and climate conditions.

QDC100 SERIES

We designed and engineered the STANLEY Commercial Hardware QDC100 Series with ultimate durability and versatility in mind. Built to provide the strength and versatility institutional and industrial markets demand, the QDC100 delivers lasting security for even the most rigorous applications.

- ANSI/BHMA Grade 1 certified
- Cast iron construction
- Customization with retrofit-compatible features and an array of options

Commercial Hardware Exit Devices

With uncompromised materials and craftsmanship, our exit devices offer premium aesthetics and functionality. Performing well above ANSI Grade 1 certification requirements, STANLEY Commercial Hardware exit devices provide security you can rely on.

NARROW STILE EXIT DEVICES

Our narrow stile exit devices combine premium design features with the durability and reliability building codes and security plans require.

- ANSI/BHMA 156.3 Grade 1 and ADA certified
- Rim, surface vertical rod and concealed vertical rod with fire-rated options
- Superior engineering for smooth and reliable functionality
- Customizable and field-sizeable for quick and simple installation



Grade 1 Closers: Build to Last

STANLEY premium door closers offer a wide range of door control solutions that exceed today's growing demand of architectural opening requirements.

- Special R-14 silicon aluminum alloy construction
- Non-handed surface and concealed closers for every type of opening
- Available in a variety of architectural finishes
- Full hydraulic checking and adjustable spring power
- Forged arms and high-impact cover

D-4550 Series

The STANLEY D-4550 Series is our best performing heavy-duty closer for institutional applications.

- Non-handed cylinder body
- R-14 silicon aluminum alloy construction for superior strength and durability
- Available in a variety of standard and heavy-duty arm configurations to accommodate a broader range of application requirements

D-3550 Series

The D-3550 Series is STANLEY'S most versatile door closer.

- Reduced body profile provides ease of installation
- Automotive grade R-14 silicon alloy construction provides dependable performance

D-1610 Series

The D-1610 Series is a slim line closer for standard aluminum storefront applications.

- Forged steel-constructed pinion and piston for reliable performance
- Non-handed cylinder body with cast aluminum construction

Grade 1 Closer Features

There are several arm and secure cover types designed to fit a variety of applications. Additionally, with an automotive grade aluminum construction and a wide range of spring power adjustments, STANLEY closers are durable and reliable for every type of application.

- **Arm Types:** Regular, top jamb, parallel, track and heavy-duty
- **Cover Options:** Metal—brass or stainless (D-4550 only) and plastic

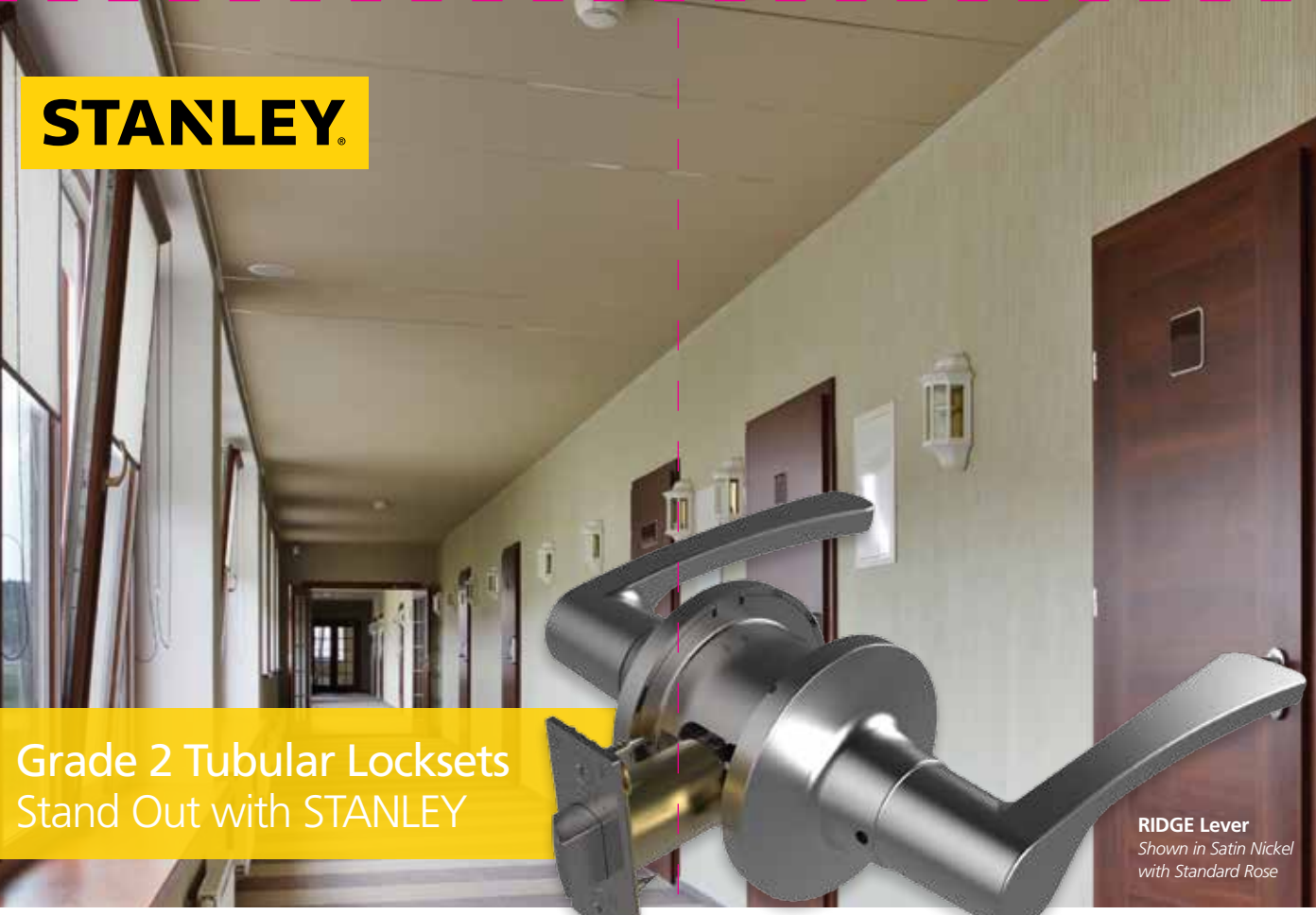

Grade 2 Tubular Locksets Stand Out with STANLEY

STANLEY's new Grade 2 mechanical levers—with unique innovations like EasyPass™ and stylized rose options—are perfect for virtually every type of light commercial or mixed-use interior opening, including offices, student housing, hotels, healthcare facilities, military barracks and more.

- **Security:** Durable, Grade 2 mechanical locks
- **Style:** Available with stylized rose options and popular finishes for all locksets and deadbolts
- **Ease:** EasyPass™ lever rotation for easy operation is not only more convenient, but has greater durability

LEVER DESIGNS AND ROSE OPTIONS

Make a statement right at the point of entry.

MIX-AND-MATCH

Suite with other STANLEY products for a consistent look.

DEADBOLTS

Standard, Decorative

INTERCONNECT

Ridge Lever Shown with Standard Rose, Ridge Lever Shown with Classic Rose

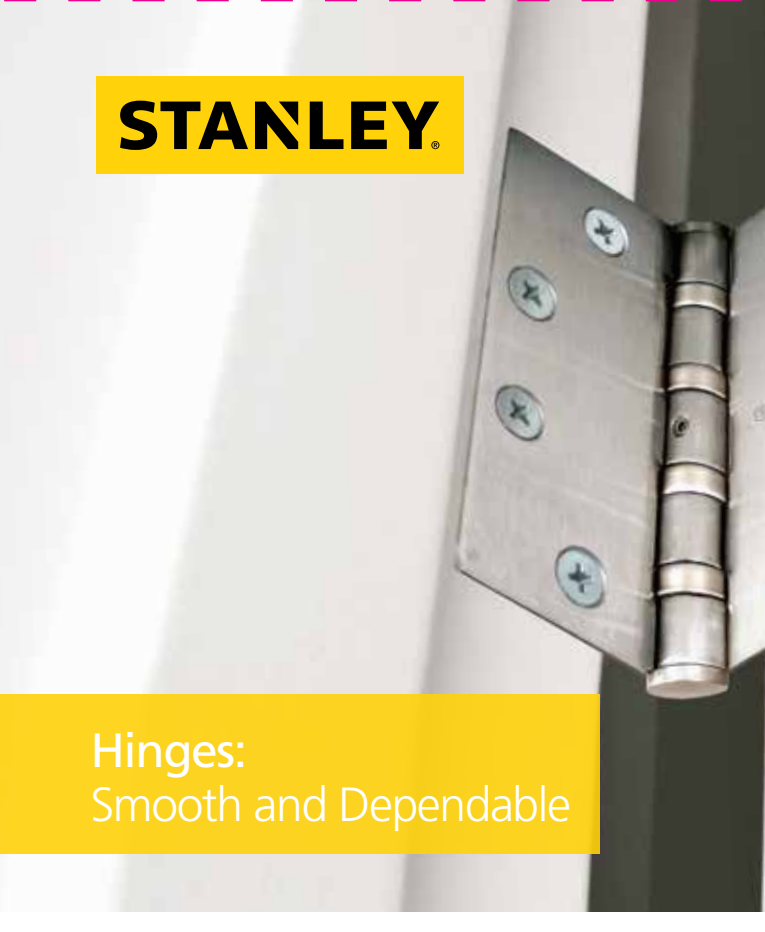

Hinges: Smooth and Dependable

A door's safe and reliable operation depends on the smooth performance of the hinge system, particularly in high-traffic areas. All STANLEY hinges conform to ANSI/BHMA standards to get the job done in any application.

- Full-mortise, half-mortise, half-surface and full-surface options
- Wide range of sizes and finishes for any door or frame application
- Package comes with fasteners and cardboard shims for quick installation
- Constructed with durable bearings and high-quality materials for long-lasting, maintenance-free operation

FBB, CB and F Series

FBB SERIES

These hinges support the vertical load of the door, as the pin bearing on the inside of the hinge knuckles supports the lateral load of the door. These ball bearing hinges meet ANSI standards and are approved for use on fire-rated doors.

CB SERIES

These concealed bearing hinges are ideal for medium to heavy weight doors in high-usage applications. They are constructed with the patented LifeSpan® bearing and exceed ANSI/BHMA Grade 1 performance standards.

F SERIES

These non-handed, plain bearing hinges are used on internal or external doors without door closers. They are available in full mortise, half mortise and half surface.



Cores and Keys: Strong Performance

Security, value and flexibility.

We designed STANLEY Commercial Hardware keying systems for compatibility with products from a variety of manufacturers.

- **More keyways:** Up to 26 different keyways available
- **More standard finishes:** Satin Brass, Oil-rubbed Bronze, Satin Chrome

The breadth of our keyway options makes it easy to find keys and cores that fit your application. And with a variety of standard finishes and quality materials that make our products long-lasting and more secure, you'll not only enjoy a great value—but also more peace of mind.

With more options, short lead times, simple installation and reliable performance, STANLEY Commercial Hardware cores and keys deliver the durable security you expect from the name more Americans trust for security products.

Core and Key Options

SMALL FORMAT INTERCHANGEABLE CORES

7CS

- Brass body with zinc face in 3 finishes
- 6- and 7-pin configurations
- Uncombined only, blank core face
- 26 available keyways

6CS

- Brass body with zinc face in 3 finishes
- 6- and 7-pin configurations
- Available combined; multiple master key levels
- 6-BEST™ "F" keyway
- 6 available keyways

6EQ

- Brass body with zinc face in 3 finishes
- 5- and 6-pin configurations; 4 core types
- Available combined or zero bitted; construction keying available
- 6 available keyways

KEYS

7AS

- Solid brass
- Uncut; stamped "Duplication Prohibited" on front
- 6- and 7-pin configurations
- 26 available keyways

6AQ

- Brass
- Key serialization or do not duplicate (DND)
- 6- and 7-pin configurations
- 7 available keyways
- 6 key types

Standard Keyways

With 26 keyways available for new construction or retrofit, plus the craftsmanship you expect from the STANLEY name, our keyways offer greater security for your facility.

- Complete line of 26 keyways
- All brass keys
- Keys stamped "duplication prohibited"

A, B, C, D, E, F, G, H, I, J, K, L, M, N, P, Q, R, BA, DD, GP, FA, TB, TC, TD, TE, SC, SD

Backed by a rich heritage, STANLEY's all-inclusive portfolio of dependable, high-quality products is easily customized for complete security solutions.

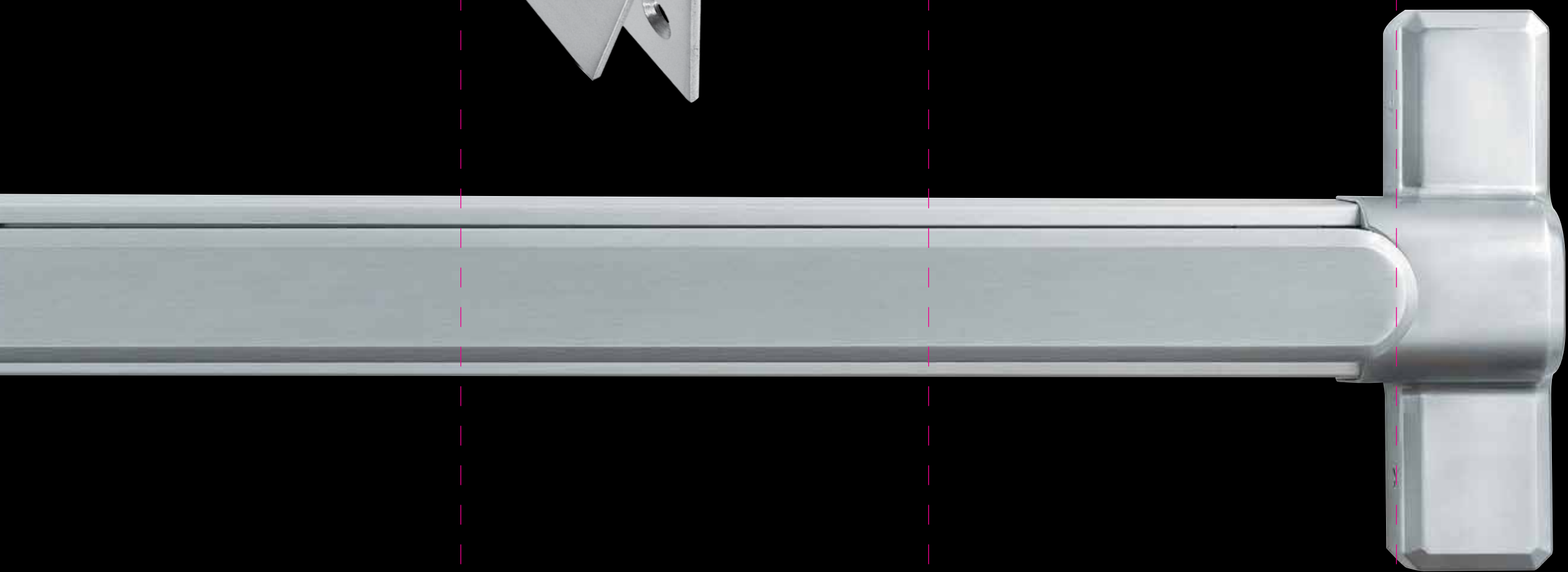

STANLEY

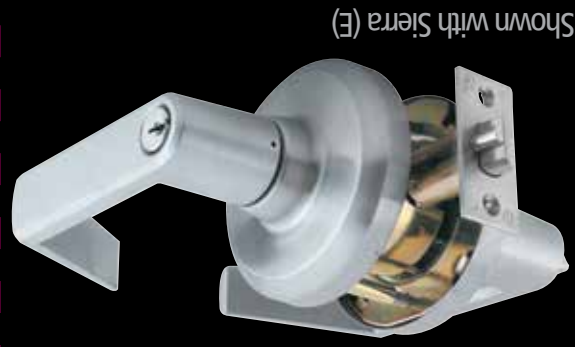

QCL100 Series
Grade 1 Heavy-Duty Cylindrical Locks

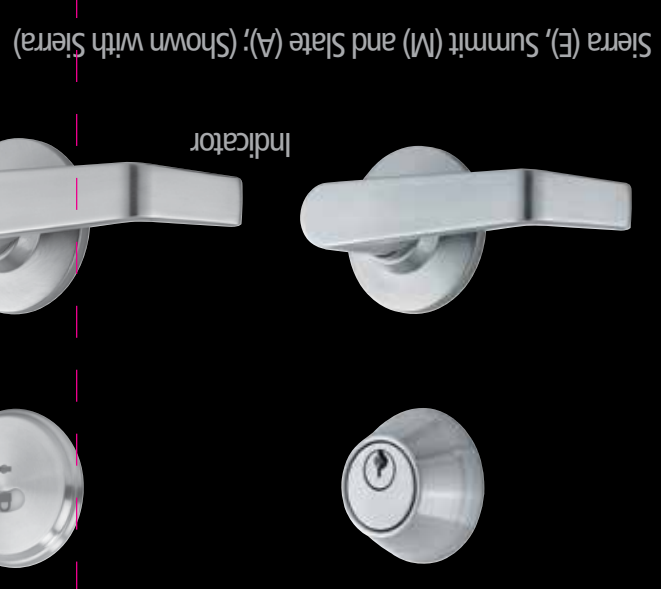

QCL200 Series
Grade 2 Standard-Duty Interconnect Locks



QMS/QME100 Series
Grade 1 Heavy-Duty Mortise Locks



QTL200 Series
Grade 2 Standard-Duty Tubular Locks



QCL200 Series
Grade 2 Standard-Duty Cylindrical Locks

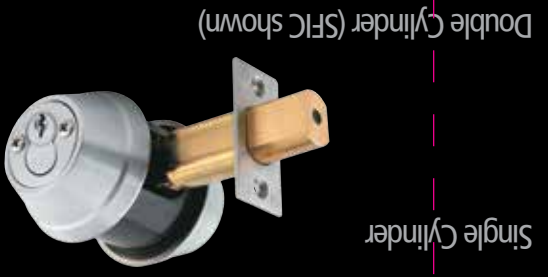

QDB100 Series
Grade 1 Heavy-Duty Deadbolts



QDB200 Series
Grade 2 Standard-Duty Deadbolts



QED100 Series
Grade 1 Heavy-Duty Exit Devices

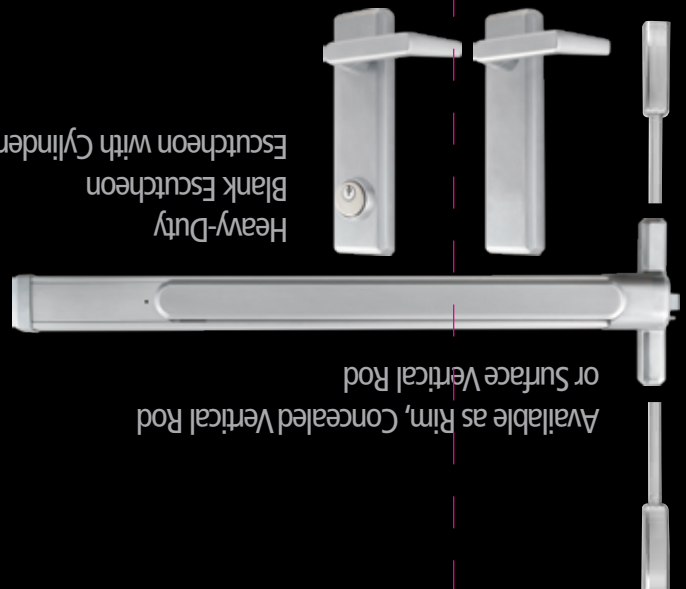

QED200 Series
Grade 1 Heavy-Duty Narrow Sillie Exit Devices



QED300 Series
Grade 1 Standard-Duty Exit Device



QDC100 Series
Grade 1 Extra Heavy-Duty Door Closers (Cast Iron)



QDC200 Series
Grade 1 Heavy-Duty Door Closers



QDC300 Series
Grade 1 Standard-Duty Door Closers

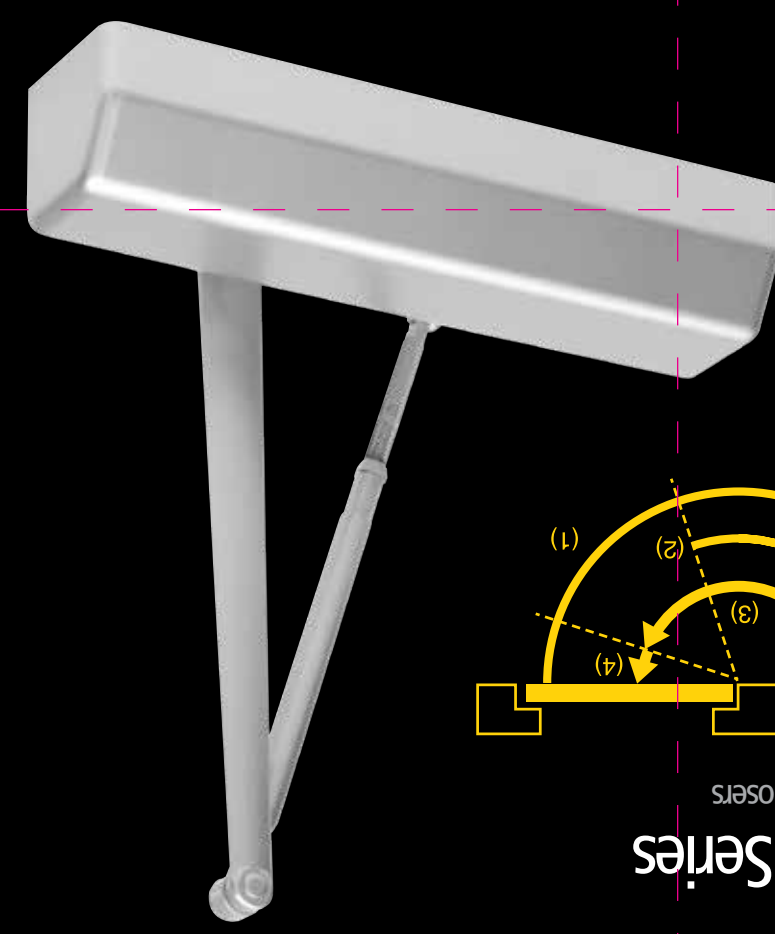

D-3550 Series
Grade 1 Door Closers

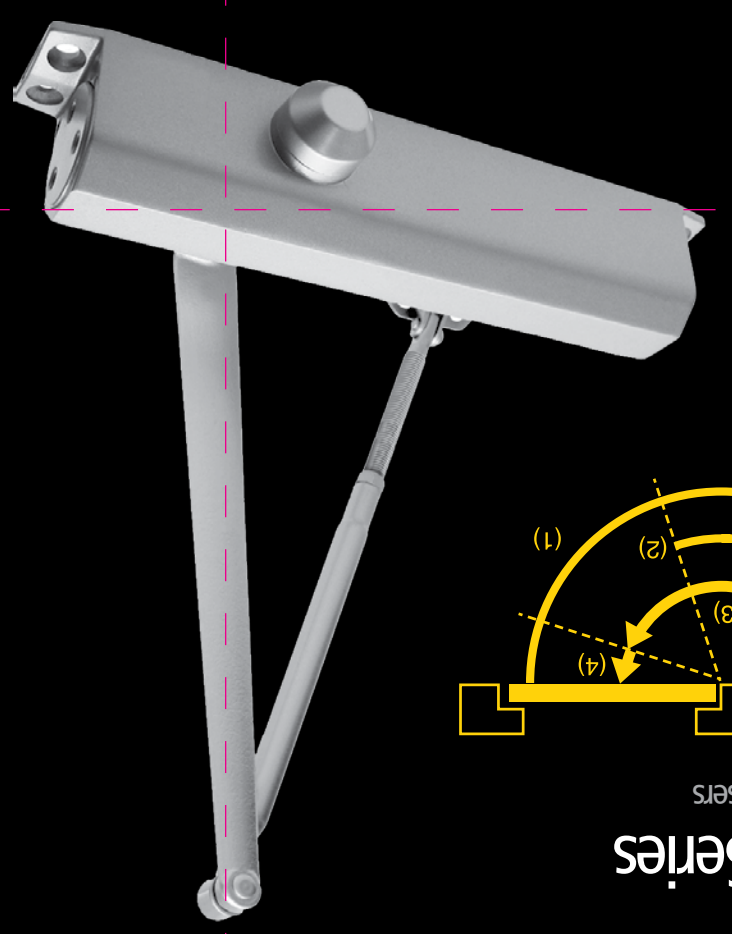

D-1610 Series
Grade 1 Door Closers

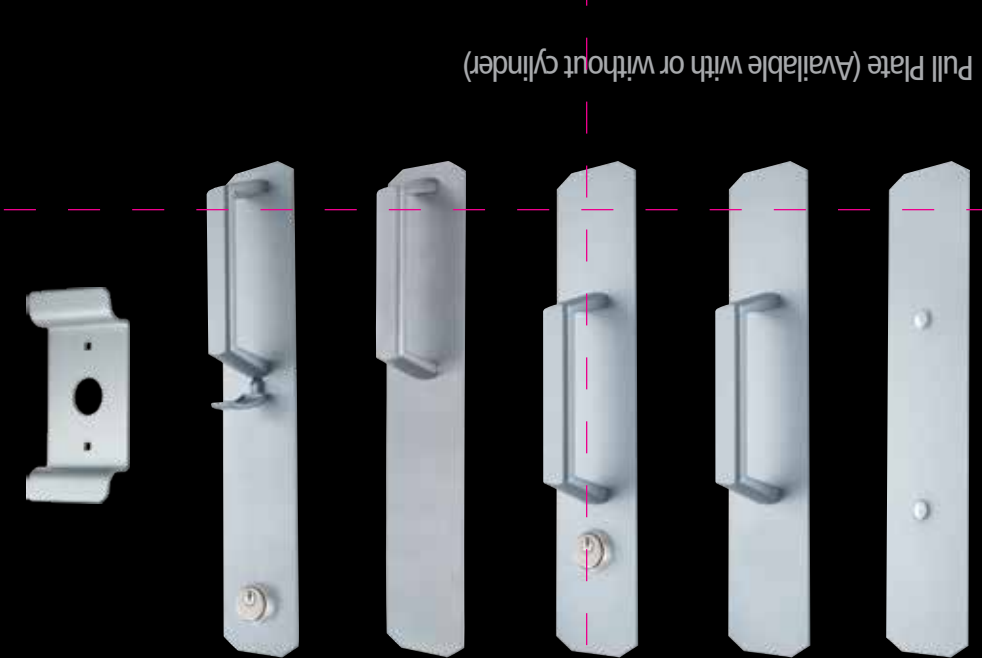

Trims & Flat Plates
Escutcheon

STANLEY

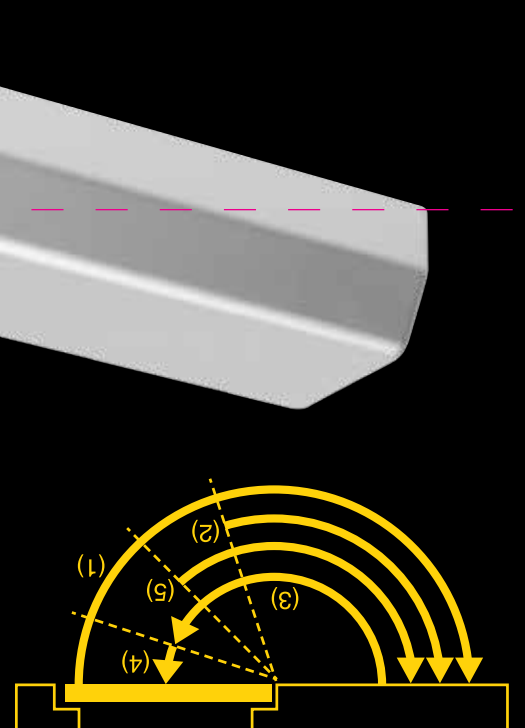

D-4550 Series
Grade 1 Door Closers

STANLEY

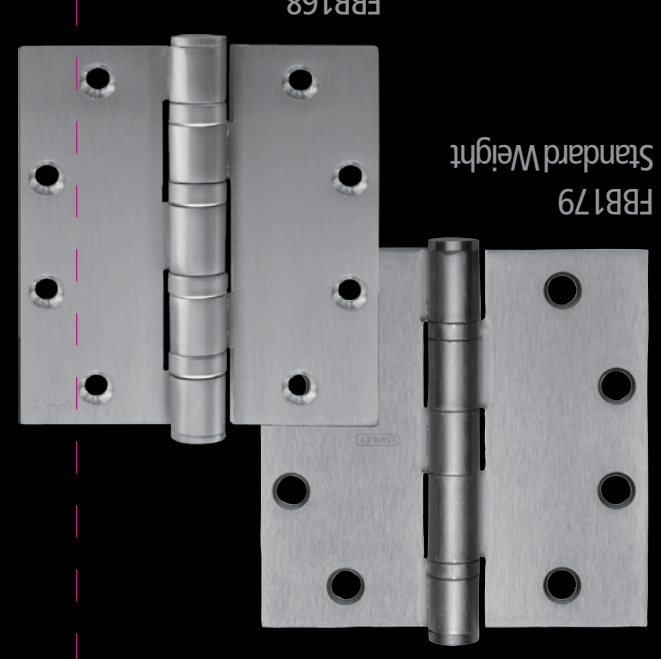

FBB Series
5-Knuckle Ball Bearing Hinges
Standard or Heavy Weight



CB Series
3-Knuckle and 5-Knuckle Concealed Bearing Hinges
Standard or Heavy Weight



F Series
Plain Bearing Hinges
Standard or Heavy Weight

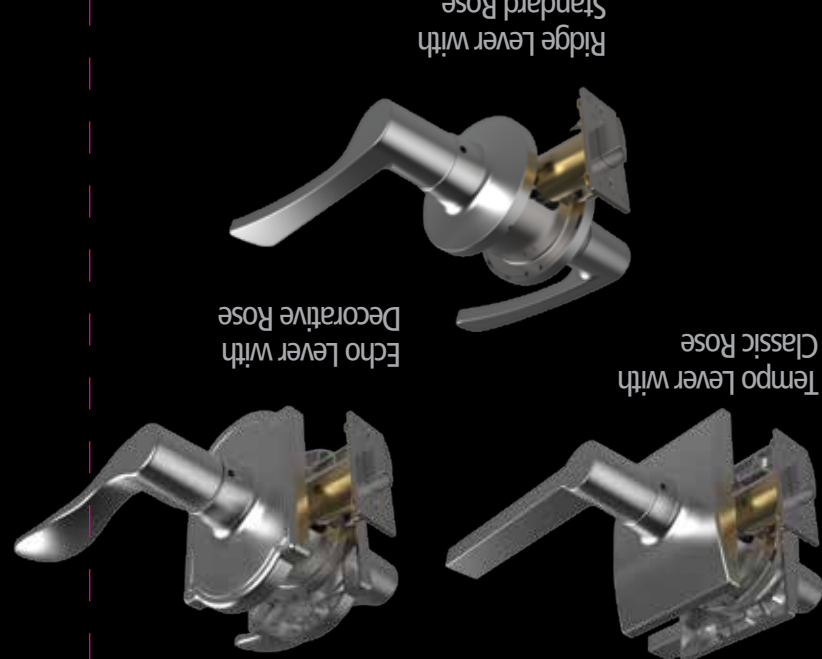

QGT200 Series
Grade 2 Standard-Duty Tubular Locksets

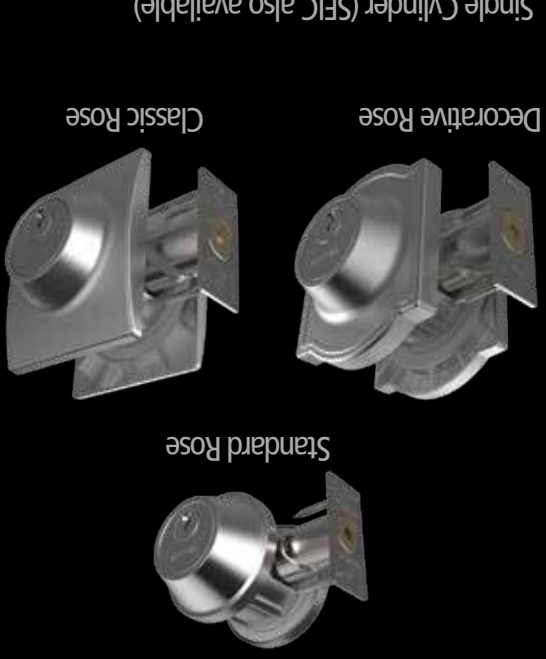

QGD200 Series
Grade 2 Standard-Duty Deadbolts

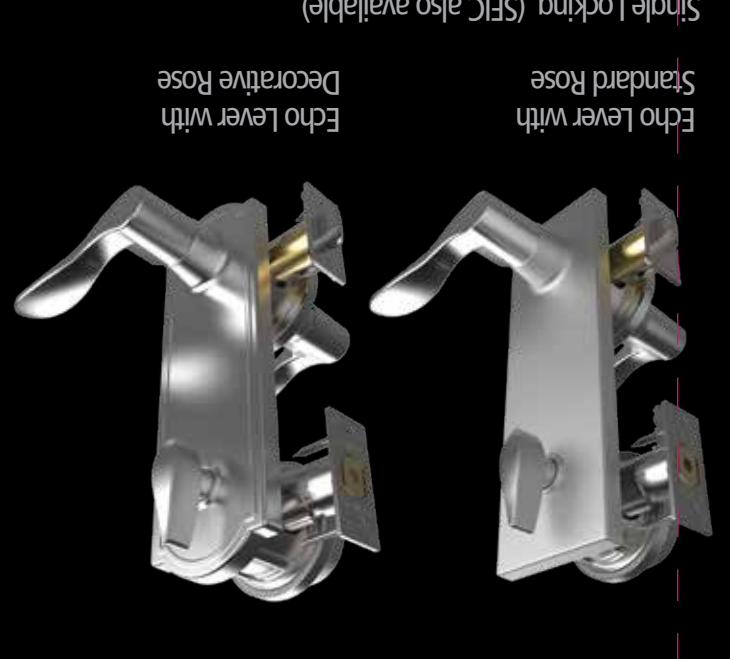

QG1200 Series
Grade 2 Standard-Duty Interconnect Locks

STANLEY

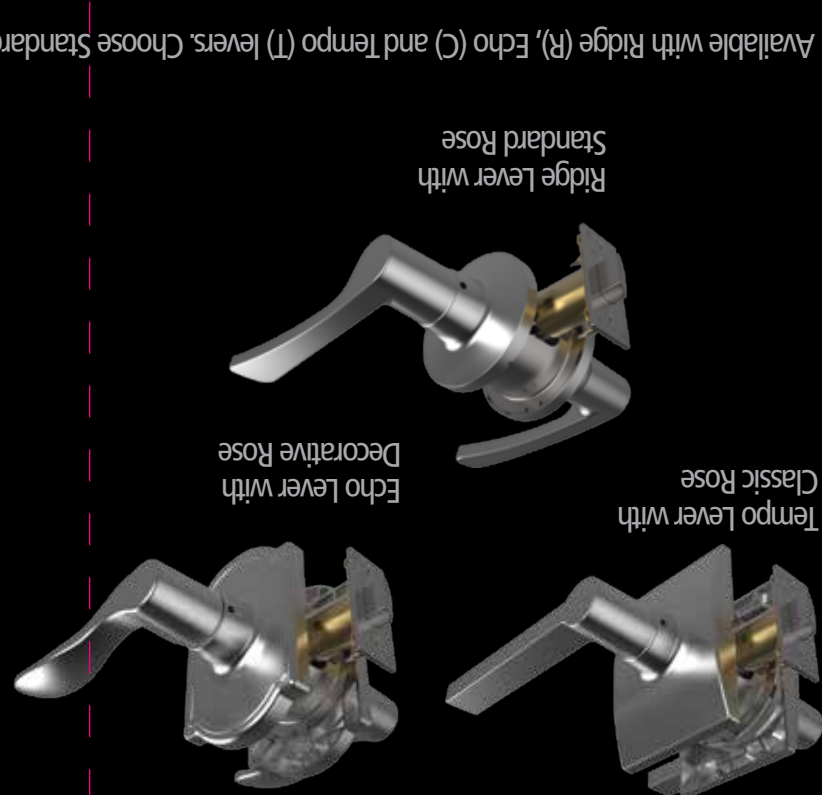

QGT200 Series
Grade 2 Standard-Duty Tubular Locksets

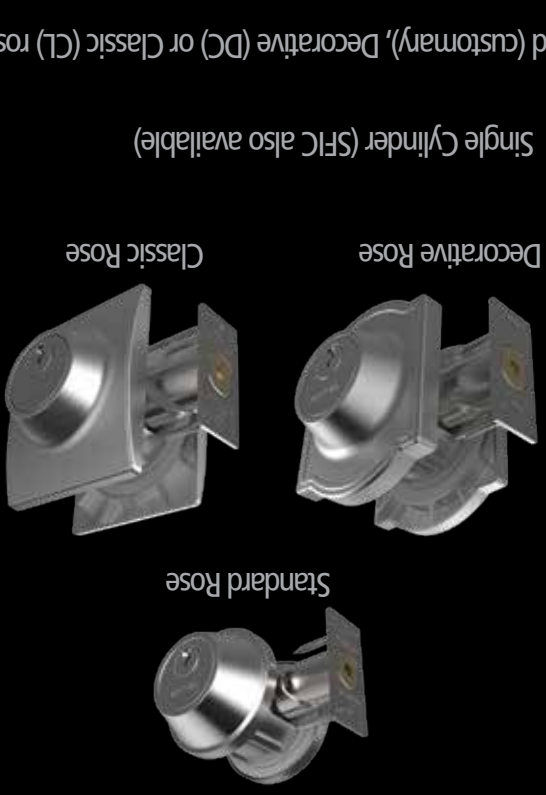

QGD200 Series
Grade 2 Standard-Duty Deadbolts



QG1200 Series
Grade 2 Standard-Duty Interconnect Locks

Available with Ridge (R), Echo (C) and Tempo (T) levers. Choose Standard (Standard), Decorative (D) or Classic (C) roses. Certain lever/rose combinations are not available.

© 2015 Stanley Security Solutions, Inc. All rights reserved. No part of this document may be reproduced or transmitted in any form or by any means, electronic or mechanical, including photocopying, recording, or by any information storage and retrieval system, without the express written permission of the author.